

Nakamura E/M APPARATUS

N99-B10-7350

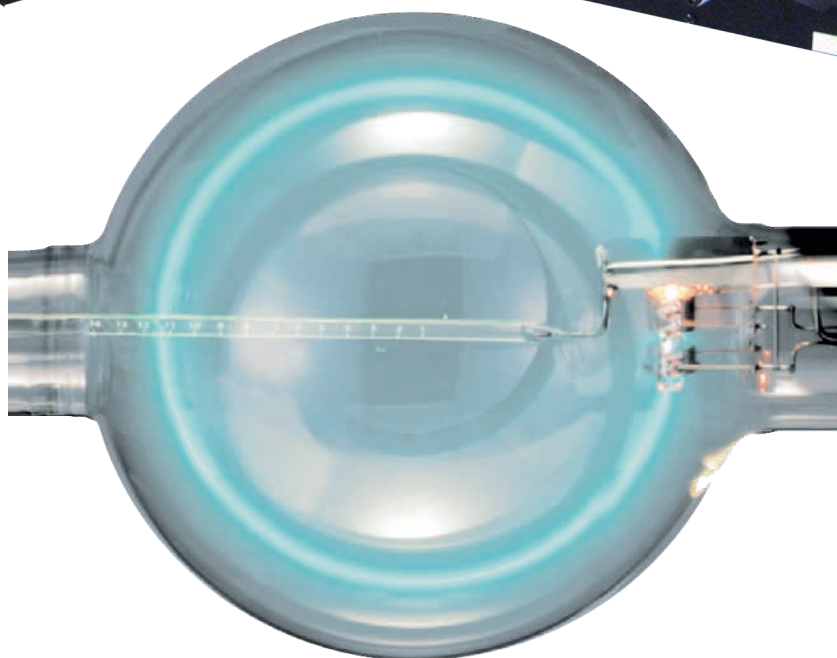
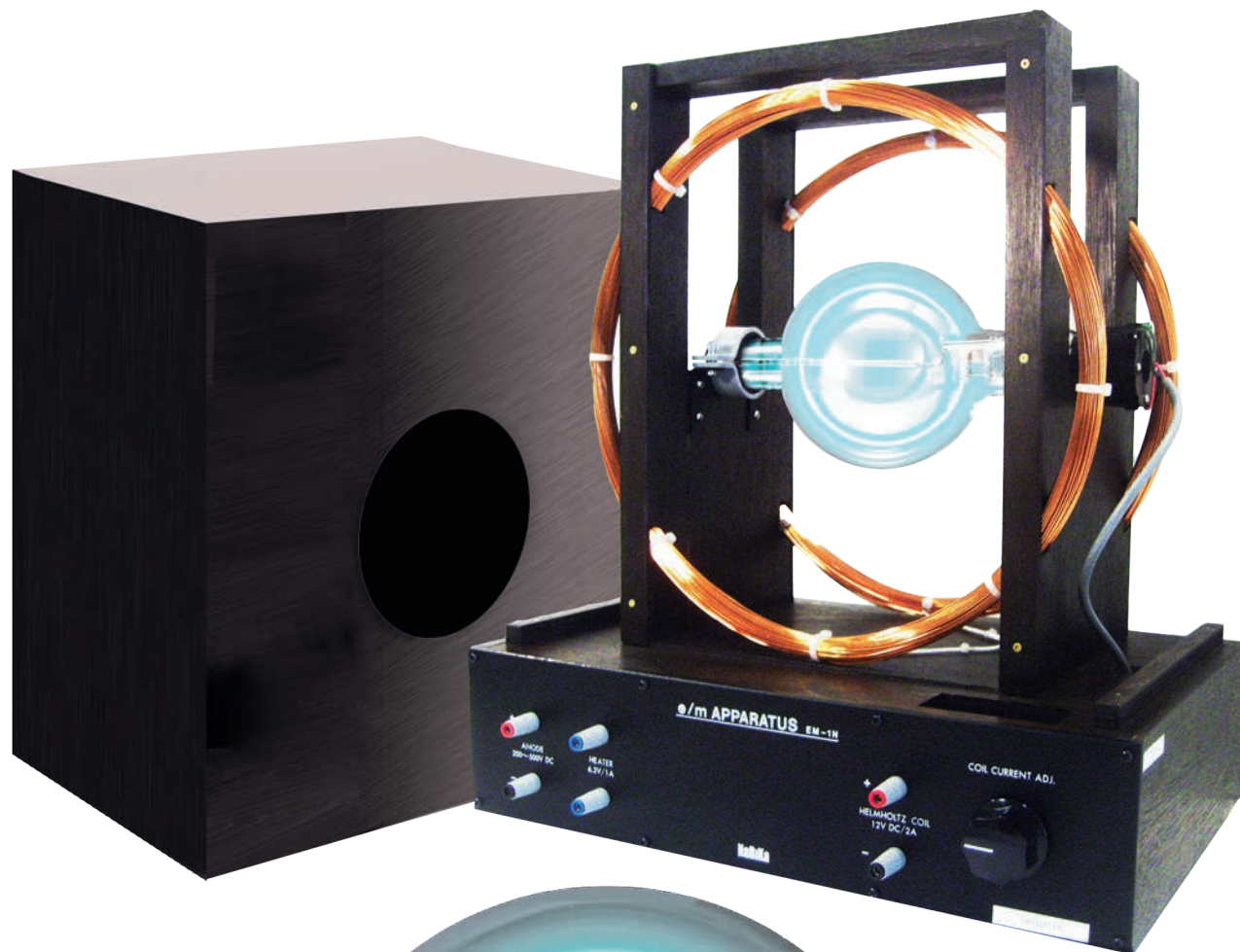

Manual of Operations

IMPORTANT!

Read the following before using this equipment:

Carefully follow all instructions and observe all precautions given in this manual



LOOK US UP ONLINE

PURPOSE

Used for the study and measurement of E/M by observing the circular paths of electrons under the influence of a uniform magnetic field.

CONSTRUCTION AND PRINCIPLES

Figure 1 shows the structure of the device.

1. The uniform magnetic field is produced by a Helmholtz coil, consisting of two parallel-mounted circular coils connected in series. Since the electrical current flows in the same direction and strength through both coils, a uniform magnetic field is created between the coils.
2. The discharge tube for measuring E/M is placed within the magnetic field created by the Helmholtz coils. The tube, which incorporates an electron gun, is filled with a low-pressure gas. The electron beam emitted by the gun appears as an illuminated circular path which can be easily observed and measured.
3. An external power supply terminal is provided on the front panel of the device, as well as a knob for adjusting the flow of current through the Helmholtz coils.

SPECIFICATIONS

COIL

Number of turns per coil: 130
Radius Interval: $R = 0.150$ m

DISCHARGE TUBE

Heater: 6.3V, 0.4A
Maximum Ratings:
Plate Voltage: 500V
Plate Current: 10mA
Measuring Life: 100 hours

FEATURES

DISCHARGE TUBE

- * Helium gas sealed within the tube facilitates the production of a bright and clear view of the electron beam.
- * An electrode is provided for absorbing electrons after they have been emitted from the electron gun and traced their circular path (patent pending). Thus, the circular tracing of the electron path is undisturbed by previously emitted electrons, contributing to more accurate measurement and extended operating life of the discharge tube.
- * The discharge tube incorporates a built-in scale for measuring the path traced by the electron beam. The graduations and numerals of the scale are illuminated by the collision of the electrons, making observation and reading even easier.

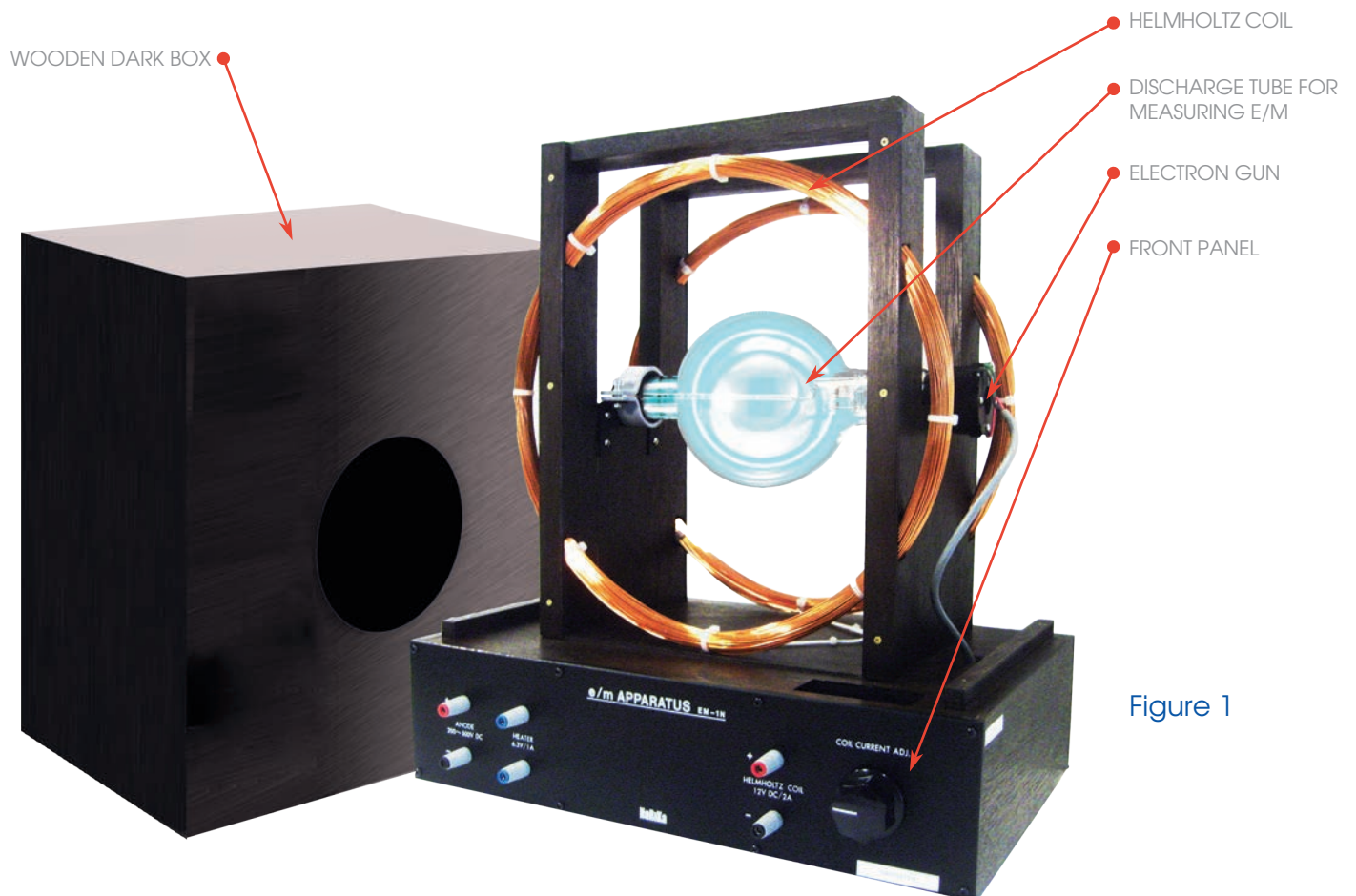

Figure 1

PRINCIPLE OF OPERATION

ACCELERATION OF ELECTRONS (ELECTRON GUN)

Figure 2 illustrates how the electron gun accelerates the motion of the electrons by means of an electromagnetic field.

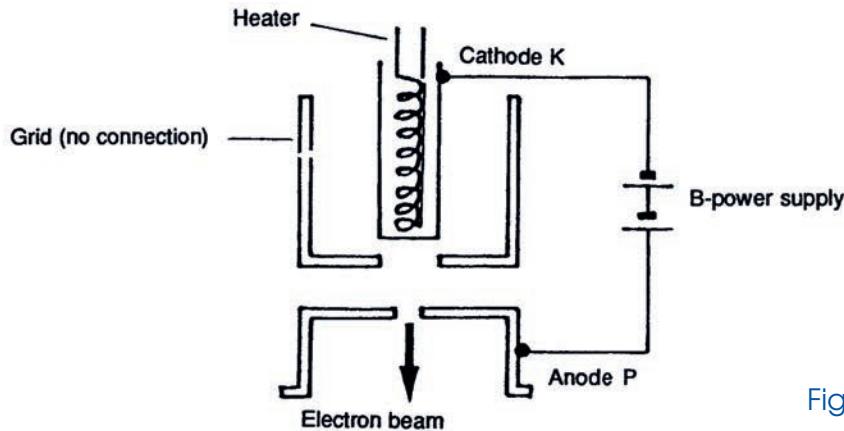

Figure 2: Electron Gun

Cathode K is heated, releasing thermions, whose motion is further accelerated by the electromagnetic field generated between Anode P and Cathode K. Under the Law of the Conservation of Energy, the velocity of the electron (m/s) when voltage V is applied at the anode can be calculated as follows:

$$\frac{1}{2} mv^2 = eV$$

$$v = \sqrt{\frac{2eV}{m}}$$

m [kg]: Mass of electron

e [C]: Elementary electrical charge

Formula 1

ELECTRON MOTION IN A MAGNETIC FIELD

Electrons which enter a magnetic field at a perpendicular angle move in a circular pattern with equal velocity on each side of the perpendicular plane against the magnetic field. Given a magnetic field with magnetic flux (B (b/m²)), where the velocity (v , m/s) of circular motion, radius (r) of the circular motion, and the Lorentz force becomes centripetal force:

$$evB = \frac{mv^2}{r}$$

$$eB = \frac{mv}{r}$$

Formula 2

In Formula 1 and 2, e/m is expressed as follows: $e/m = \frac{2V}{R^2B^2}$

Formula 3

HELMHOLTZ COIL

Two circular coils of equal radius are mounted in parallel on a common axis. When an electrical current is applied to the coils, so that it follows in the same direction and strength, a uniform magnetic field is formed around the common axis between the coils. This is the underlying principle applied to the operation of this device.

According to Bio-Savart's Law, given intensity H (A/m) of magnetic field between the two coils, radius r , and current intensity I (A), the following formula is obtained.

$$H = \frac{B}{5\sqrt{5}} \quad \frac{I}{R} = 0.7155 \times \frac{I}{R} \text{ [A/m]}$$

Formula 4

Accordingly, when there are N turns of wire in each coil, the intensity of the magnetic field is multiplied N times. With permeability in a vacuum, $4\pi/10^7$, intra-coil magnetic flux density is as follows:

$$B = 0.7155 \times \frac{4\pi}{10^7} \frac{NI}{R}$$

$$= 8.99 \times 10^{-7} \frac{NI}{R} \text{ [Wb/m}^2\text{]}$$

Formula 5

Thus, since the coils in this apparatus are constructed with 130 turns and a radius of 0.150 m, students can use observed values to determine the electron-to-mass ratio based on the following formula which determines B :

$$B = 7.79 \times 10^{-4} I \text{ [Wb/m}^2\text{]}$$

Formula 6

EXPERIMENTAL PROCEDURES

PREPARATION

(1) CONFIGURATION

- Power supply unit, PS-2 for vacuum tubes (B)
- Regulated DC power supply unit, RPS-1000N or 6~12V storage battery
- DC voltmeter (500V)
- DC ammeter, measurements up to 2A
- Magnetic needle

NOTE: Voltmeter and Ammeter not required when only observation is to be performed.

(2) CONNECTING THE POWER SUPPLY SYSTEM

- Connect a 6.3V power supply to the power terminal of the heater on the main body of the unit (either AC or DC).
- Connect a 0~500V DC power supply to the B-power terminal of the main unit. (Red terminal P is (+), black terminal K is (-)).

NOTE: The power supply requirements can be met by the power supply unit for vacuum tubes.

- Connect the DC power supply to the coil power supply terminal on the main unit. (Red terminal is (+), black terminal is (-)).

NOTE: A regulated DC Power supply (0~15V) should be used for this purpose. When using this type of power supply, turn the knob of the coil power terminal fully clockwise and set variable resistance to 0. When using storage batteries (6~12V), turn the knob of the coil power supply terminal fully counterclockwise and set the resistance to maximum.

OBSERVATION AND EXPERIMENTATION

(1) CIRCULAR MOTION OF ELECTRON BEAM

- First, set the voltage for B-power supply and coil to the minimum level and then turn on the unit's main power switch.
- When the cathode glows red hot, gradually raise the voltage of the B-power supply as you observe the discharge tube. The illuminated electron beam will gradually appear at just under 200V.
- Gradually increase the voltage of the coil-power supply. (When a storage battery is used, turn the adjustment knob for the coil current clockwise.)

The increased voltage in the coils will raise the intensity of the magnetic field until the electron beam is bent into a circular pattern. When the path of the beam becomes circular, use a magnetic needle to check the polarity of the magnetic field formed between the Helmholtz coils. This will make it possible to confirm the relation of the magnetic field with the direction of Lorentz force.

NOTE: If the electron gun is not pointed downward, a spiral motion of the beam will be observed. In this case, loosen the mounting screw of the discharge tube and adjust the position of the tube until the electron gun is in the proper orientation.

(2) SPIRAL MOTION

Loosen the mounting screw of the discharge tube and slightly re-adjust the position of the tube. The electron beam should then assume a spiral motion. The shape of the spiral can be changed by varying the intensity of the coil current, the voltage level of the B-power supply, or the position of the discharge tube.

(3) AFFECT OF BRINIGING A MAGNET NEAR THE DISCHARGE TUBE

The magnetic field of a magnet is brought near the discharge tube, which generates complicated patterns in the motion of the electron beam.

CAUTION: If the B-voltage is raised too high, the operational life of the discharge tube will be shortened. Consequently, be careful when raising the B-voltage.

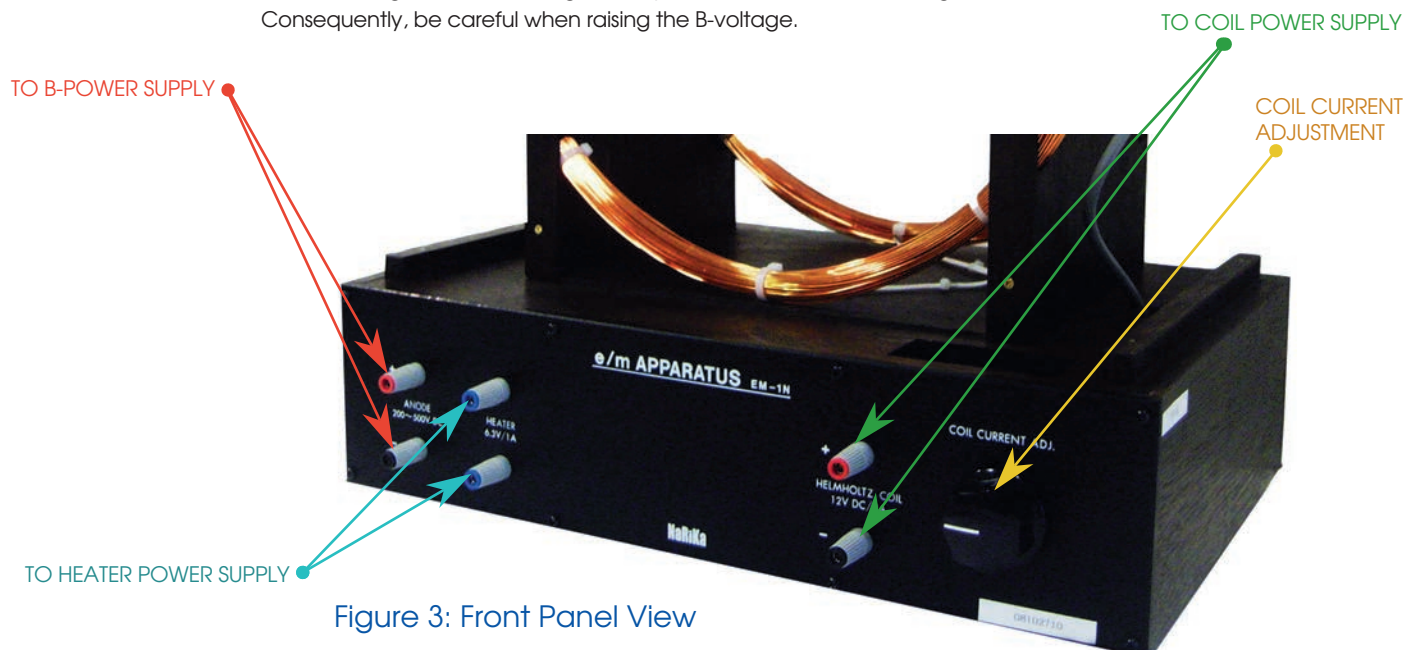

Figure 3: Front Panel View

MEASUREMENT

SETTING UP TESTING DEVICE AND INSTRUMENTS

1. Use a voltmeter and ammeter which are not connected to the power supply system and which meet the required level of accuracy for measurement.
2. In order to minimize the influence of geomagnetism, use a magnetic needle to locate magnetic North and align the main unit of the device so that the faces of the Helmholtz coils are parallel to the needle. This will have the effect of reducing the influence of geomagnetism on the magnetic field parallel to the coil axis.
3. Connect the power supply, voltmeter, and ammeter to the appropriate terminals of the main unit, as shown in Figure 4.

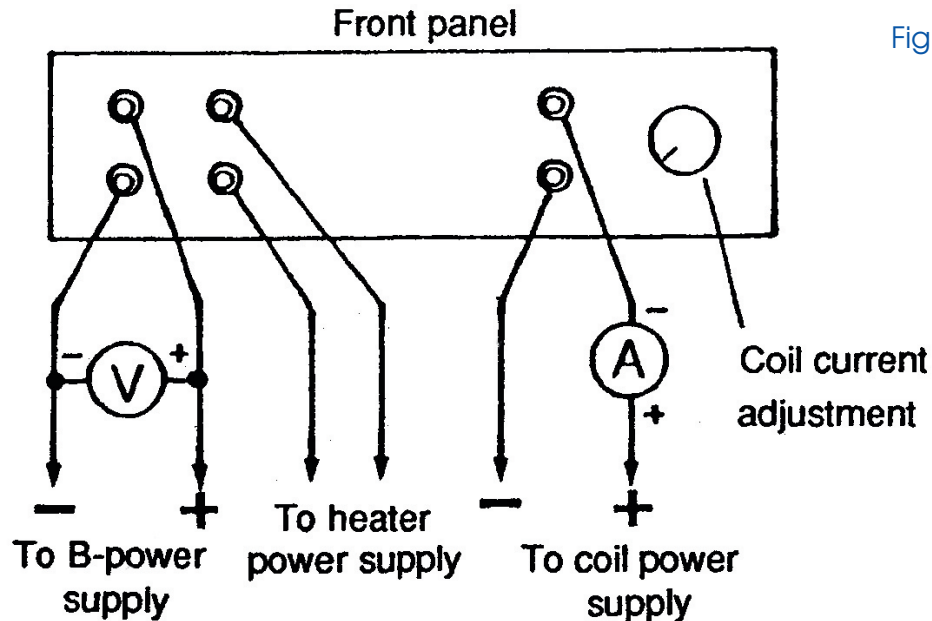

Figure 4: Wiring

NOTE: The influence of geomagnetism or other sources of magnetic fields can be observed by the deflection of the circular motion of the electron beam while the main unit is rotated. The magnitude of this deflection is greater when a small current is flowing through the coils.

OPERATION

Set up the device as described in the, "Setting Up Testing Devices and Instruments", section, steps (1) to (3), to produce a circular motion and calculate E/M by measuring the voltage (V) applied to the B-power supply, current (I) flowing through the coils, and diameter (2r) of the circle traced by the electron beam.

EXAMPLE OF MEASUREMENT

With B-voltage set at 300V, adjust the coil current to produce a circular path of 100 mm in diameter. These values and the obtained measurement of 1.48A are applied in the following formula:

$$[V = 300V, I = 1.48A, r = 0.0500m]$$

Formula 7

$$\begin{aligned} e/m &= \frac{2V}{r^2 B^2} = \frac{2V}{(r \times 7.79 \times 10^{-4} \times I)^2} \\ &= \frac{2 \times 300}{(0.05 \times 7.79 \times 10^{-4} \times 1.48)^2} = 1.81 \times 10^{11} \text{ [C/kg]} \end{aligned}$$

$$[\text{Reference}] e/m = 1.7588 \times 10^{11} \text{ [C/kg]}$$